

# LIGRE

## INSTRUCTIONS PORTAFILTER MACHINE YOUN

Translation of original user manual

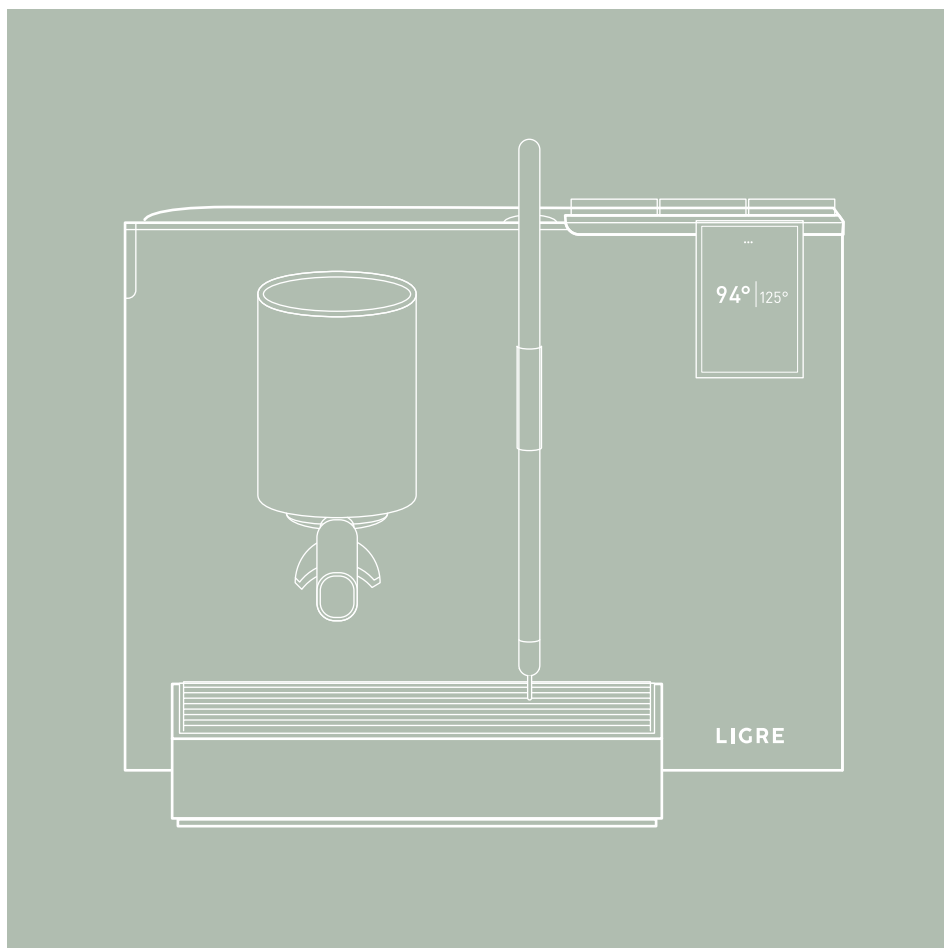

---

## TABLE OF CONTENTS

|   |  |    |
|---|--|----|
| 1 | Safety   | 4  |
| 2 | Scope of delivery                                  | 7  |
| 3 | LIGRE youn   | 8  |
|   | 3.1 Control elements                               | 9  |
|   | 3.2 Accessories                                    | 10 |
| 4 | Setup  | 11 |
|   | 4.1 Setting up and connecting                      | 11 |
|   | 4.2 Preparing LIGRE youn for use                   | 12 |
| 5 | Operation  | 15 |
|   | 5.1 LIGRE guide                                    | 15 |
|   | 5.2 Brewing espresso                               | 15 |
|   | 5.3 Changing flavour and taste                     | 18 |
|   | 5.4 Preparing milk foam                            | 22 |
|   | 5.5 Obtaining hot water                            | 24 |
|   | 5.6 Rinsing the brew group with LIGRE shpla        | 24 |
|   | 5.7 Emptying the drip tray                         | 26 |
| 6 | The settings                                       | 27 |
|   | 6.1 Brewing parameters                             | 27 |
|   | 6.2 LIGRE sensory profiles                         | 28 |
|   | 6.3 Boiler temperature                             | 28 |
|   | 6.4 Timer  | 29 |
|   | 6.5 LIGRE eco mode                                 | 30 |
|   | 6.6 Water quantity for hot water and espresso      | 31 |
|   | 6.7 General settings and information               | 32 |
| 7 | The cleaning and maintenance                       | 33 |
|   | 7.1 Cleaning the steam lance                       | 33 |
|   | 7.2 Cleaning the portafilter machine and drip tray | 34 |
|   | 7.3 Cleaning the brew group and portafilter        | 35 |
|   | 7.4 Descaling the portafilter machine              | 39 |

|     |  |    |
|-----|--|----|
| 7.5 | Replacing the boiler water             | 40 |
| 7.6 | Transport drainage                     | 40 |
| 7.7 | Maintenance                            | 41 |
| 8   | Technical data                         | 42 |
| 9   | The troubleshooting                    | 43 |
| 10  | On environmental protection and energy | 45 |
| 11  | The warranty                           | 46 |
| 12  | The LIGRE Service                      | 47 |

---

**NOTE**



On our website at [ligre.com/service](https://ligre.com/service) you will find lots of helpful information and how-to videos on operating and maintaining the LIGRE youn, as well as FAQs, instructions and other documents.

---

# 1 SAFETY

## GENERAL INFORMATION

- Read the user manual
- Retain the user manual
- Check appliance for transport damage and, if found, do not plug it in

## INTENDED USE

The LIGRE youn portafilter machine is used for preparing espresso, heating milk and water, and frothing milk both for private domestic use and for businesses such as offices, studios or similar, but not for the continuous mass production of foodstuffs.

Any other use is not considered to be in line with the intended purpose and is therefore dangerous. LIGRE assumes no liability for the consequences of improper use.

## RESTRICTION OF THE USER GROUP

This appliance can be used by children over the age of 8 years and people with reduced physical, sensory or mental abilities or a lack of experience or knowledge if they are supervised during use or have been trained in the safe use of the appliance and have understood the resulting dangers.

Children are not permitted to play with the appliance.

Children are not permitted to clean or maintain the appliance unless they are over the age of 8 years and are supervised.

Keep the appliance and cable out of reach of children under 8 years of age.

## SAFETY INFORMATION

---



### DANGER

Risk of suffocation

Children may pull the packaging over their heads or wrap themselves in it and suffocate.

- Keep the packaging material away from children.

Children may swallow or inhale small parts and choke on them.

- Keep small parts away from children.
- 



### DANGER

Risk of electric shock

There is a risk of electric shock due to improper installation.

- Only operate the appliance according to the specifications on the type plate and in the technical data.
- Only connect the appliance to a properly installed and earthed wall socket.

There is a risk of electric shock if the portafilter machine is damaged.

- Only operate the appliance if the cable and mains plug are undamaged.
- Never pull on the cable to disconnect the appliance from the power supply.
- Only operate the appliance in a fault-free condition.

There is a risk of electric shock due to contact with water or water vapour.

- Do not immerse the appliance in water or hold it under running water.
  - Keep the cable and mains plug away from water and water vapour.
  - Only operate the appliance indoors.
  - Unplug the appliance before cleaning it.
-

**DANGER**

Risk of electric shock

There is a risk of electric shock due to improper repairs.

- Never open the appliance.
  - Only have repairs undertaken by trained experts.
  - If the power cable for the appliance is damaged, it must be replaced by the manufacturer, its customer service or a similarly qualified specialist in order to avoid hazards.
  - Only use original spare parts.
- 

**WARNING**

Fire hazard

The portafilter machine gets hot.

- Ventilate the appliance sufficiently.
- Never operate the appliance in a cabinet.

Extended powers cables or unauthorised adapters may cause fires.

- Do not use extension cables or power strips.
  - Only use adapters and power cables approved by the manufacturer.
  - If necessary, contact a qualified electrician to make adjustments to the house wiring.
- 

**WARNING**

Risk of burns

Some parts of the portafilter machine get very hot during operation.

- Never touch hot parts of the appliance.
  - Switch off the appliance and allow it to cool down before touching any hot parts.
- 

**WARNING**

Risk of scalding

Freshly prepared drinks are very hot.

- Allow the drinks to cool before consuming.
  - Avoid skin contact with hot liquids and vapours.
-

## 2 SCOPE OF DELIVERY

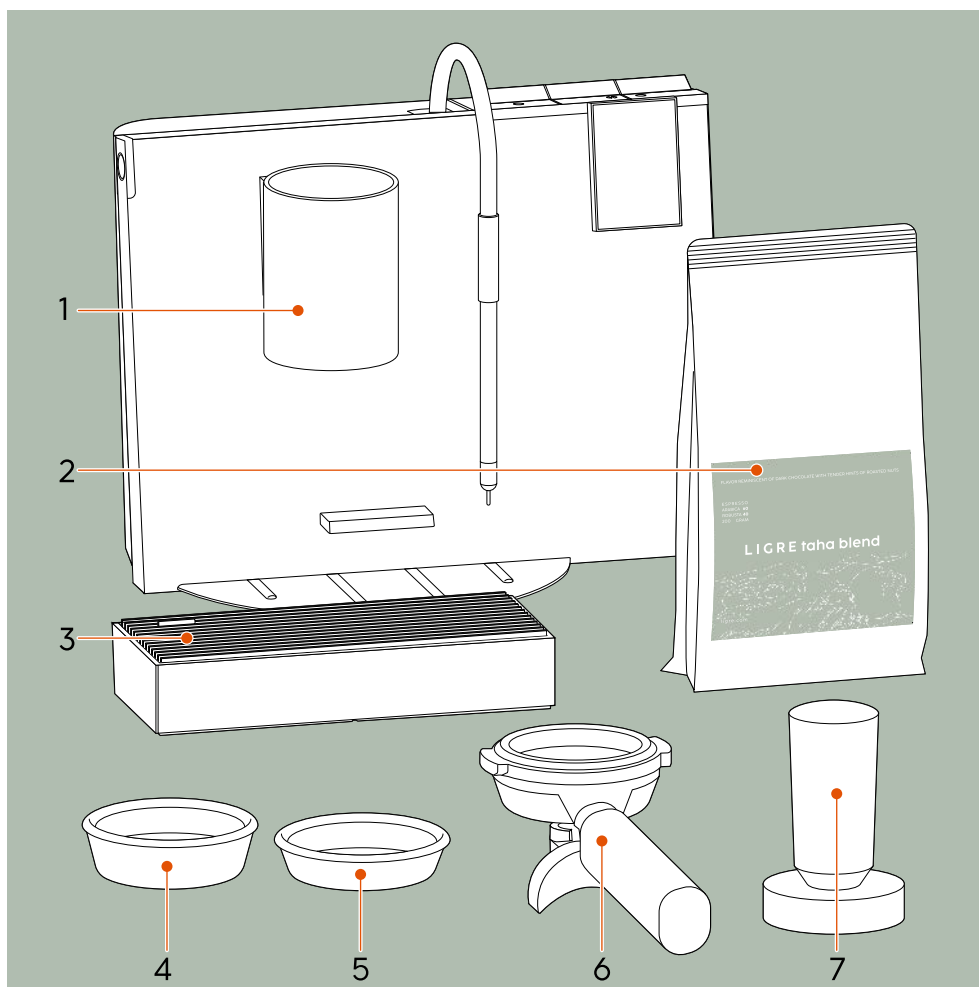

- 1 Portafilter machine LIGRE youn
- 2 Coffee beans LIGRE taha blend 200 g
- 3 Drip tray
- 4 Single filter basket
- 5 Blind filter
- 6 Double portafilter with double filter basket
- 7 Tamper

LIGRE youn quickstart guide and quick reference guide  
Optional adapter for power plugs (for CH, DK, UK)

### 3 LIGRE YOUN

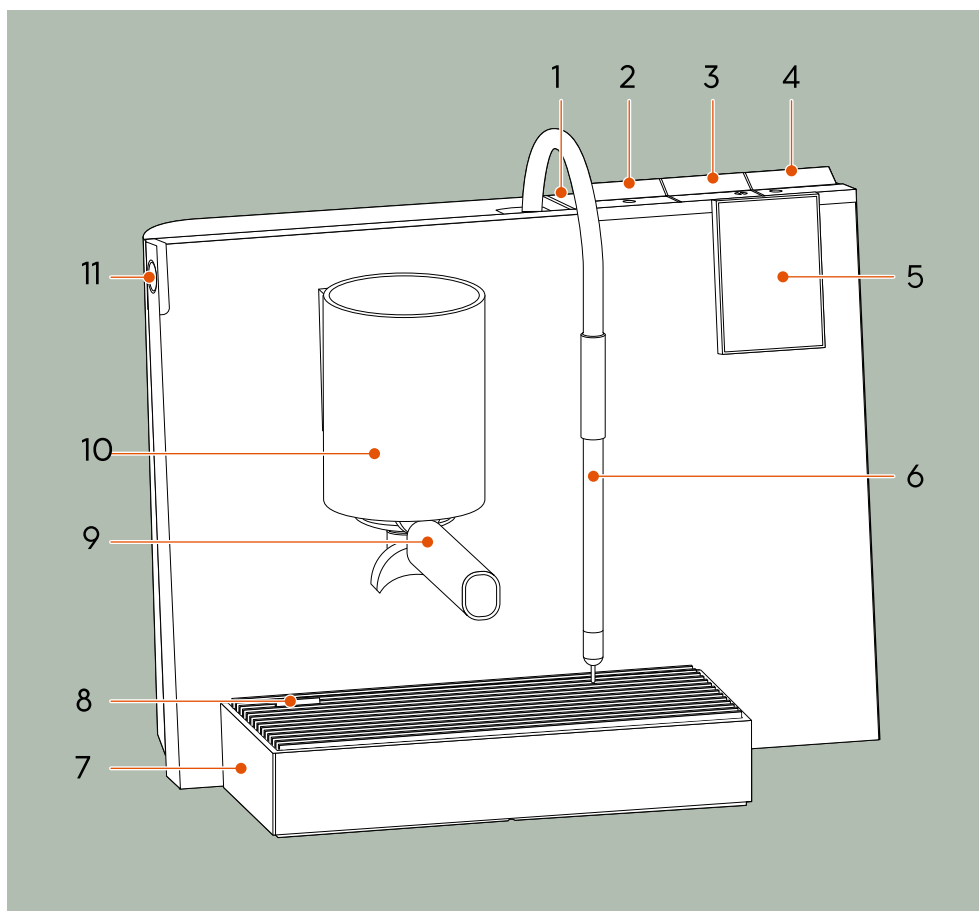

1 Lid of the water tank

2 Hot water button

3 Espresso button

4 Steam button

5 Touchscreen

6 Steam lance

7 Drip tray

8 Drip rack

9 Portafilter

10 Brew group

11 Standby button

### 3.1 CONTROL ELEMENTS

So that you can concentrate fully on preparing your espresso, we have deliberately designed the operating elements of your portafilter machine to be simple.

#### STANDBY BUTTON

You can use the standby button to switch your portafilter machine on or into standby mode. This allows you to save energy and still ensure that your portafilter machine heats up quickly.

#### TOUCHSCREEN

Most of the operation is carried out via the touchscreen on your LIGRE youn. The intuitive user interface helps you to quickly find your way around.

The home screen shows the temperature of the brew group on the left-hand side and that of the boiler on the right-hand side. If you touch the display on the left-hand side, you will be taken to the menu “Coffee settings”. If you touch the display on the right-hand side, you have access to the menu “Boiler temperature”. You can return to the home screen by tapping the three dots at the top of the touchscreen.

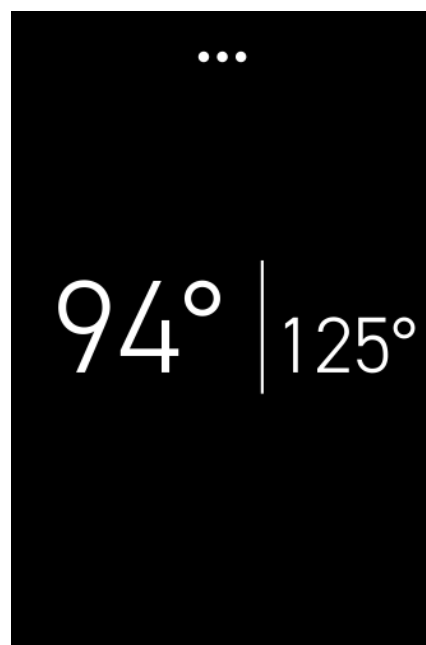

You can access other functions and general settings for your LIGRE youn by tapping on the three dots at the top of the touchscreen.

#### BUTTERFLIES HOT WATER, ESPRESSO AND STEAM

With the buttons on the top, the LIGRE butterflies, you can easily draw hot water, brew espresso or prepare milk foam. The butterflies each have two functions:

- Press  
Press a butterfly to activate the LIGRE easy mode, with which you can easily obtain hot water, espresso or steam.
- Pull  
If you pull a butterfly towards you, you start the LIGRE nerd mode. In nerd mode, you can control the extraction time as you wish. The button remains in this position until you tilt it back again and nerd mode stops.

### 3.2 ACCESSORIES

You can find the following cleaning products and accessories in our LIGRE webshop so that you can enjoy your coffee experience to perfection.

|                              |   |
|------------------------------|---|
| LIGRE<br>Milk system cleaner | To keep the LIGRE foamer hygienically clean, use the LIGRE milk system cleaner regularly. If milk residue remains on the steam lance, harmful residue can form and subsequent cleaning becomes considerably more difficult.   |
| LIGRE<br>Cleaning tabs       | Coffee residue in the brew group lead to a change in the flavour of the brewed coffee after a short time. Weekly cleaning of the brew group is particularly recommended to ensure that your coffee always tastes good.  |
| LIGRE<br>Descaling tabs      | As limescale in the water can impair the function of your youn and cause an irreparable defect, you should always descale your LIGRE youn on a regular basis.   |
| LIGRE<br>Accessories         | Our designers have thought of everything and created additional accessories for you. Take a look at the LIGRE accessories in our webshop. There you will find single and double portafilters as well as tampers, levellers and barista brushes in various wooden versions or tamper mats made of real leather, milk jugs, various speciality coffees and much more. |

## 4 SETUP

### 4.1 SETTING UP AND CONNECTING



#### DANGER

Risk of electric shock

There is a risk of electric shock due to contact with water or water vapour.

- Do not place the appliance on a surface where a jet of water might reach it.

1. Please read the safety instructions in 1 "Safety".
2. Place your portafilter machine on a clean, horizontal and stable flat work surface.
3. To adjust the cable length, push the excess cable on the back into the inside of the portafilter machine and fix it carefully in the recess provided so that the cable is not trapped under the portafilter machine.
4. Make sure that the portafilter machine is stable and does not wobble.
5. Insert the mains plug into the wall socket.
6. Place the drip tray underneath the brew group.

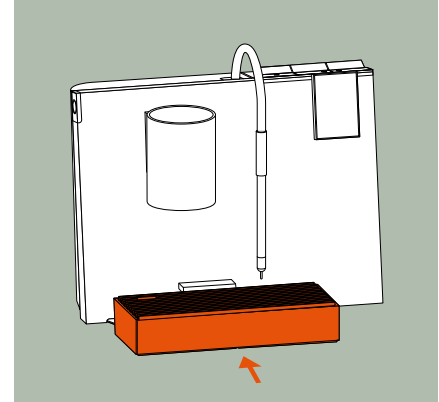

---

## 4.2 PREPARING LIGRE YOUN FOR USE

Before you brew your first espresso, you need to set up your LIGRE youn.

1. Switch the machine on using the standby button in the top left-hand corner.
2. Follow the instructions on the touchscreen when switching on for the very first time. Your LIGRE youn will guide you in making some important basic settings.

---

### NOTE



Unsuitable water will damage the portafilter machine or impair its function.

- Only fill the water tank with water at a maximum temperature of 35 °C.
- Never fill with carbonated water.
- Please do not use distilled water or pure osmosis water. The lack of minerals in the water can result in the portafilter machine's sensors not recognising the water in the boiler, which can lead to malfunctions. For the best flavour experience and perfect function, please use mineral-rich drinking water.

---

### SETTING THE WATER HARDNESS

When you switch on your LIGRE youn for the very first time, the portafilter machine will guide you through a few basic settings on the display. One of these is setting the water hardness. The correct water hardness is important so that your portafilter machine alerts you to the need for descaling at the right time.

1. Fill a small container with drinking water.
2. Use the enclosed test strip to measure the hardness of the water.
3. Follow the instructions on the touchscreen.

---

### NOTE



When using a water filter or a central descaling system  
If you use a commercially available water filter or a central descaling system is installed in your home, please set the hardness level to “softened”. This takes into account the special composition of the water from the ion exchanger.

---

If you have neglected to set the water hardness on the portafilter machine right at the start, you can still call up the menu for settings later.

1. Open the menu “Settings” using the three dots at the top of the touch-screen.
2. Select the menu item “General”.
3. Tap on “Water hardness” and set the hardness level of your water and confirm with “OK”.
  - ▶ Your LIGRE youn is now set to the local water hardness.

### RINSING THE PORTAFILTER MACHINE

Your new portafilter machine has been thoroughly tested by us for functionality and quality during production. It should be rinsed twice before first use to remove any residue. This ensures that the system is optimally prepared and the first espresso can start by using pure water.

Fill the machine with water:

1. To open the water tank, tap the front edge of the lid and remove the lid.
2. Wipe the lid with a damp cloth.
3. Remove the water tank from the portafilter machine, rinse it out, fill it with fresh water and reinsert the water tank.

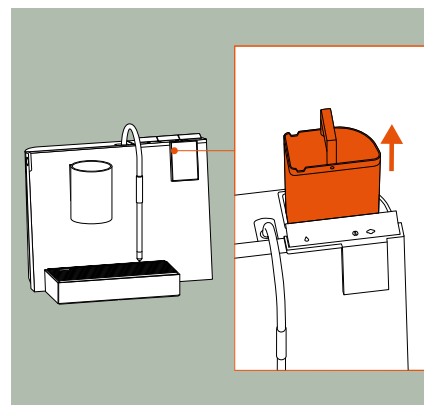
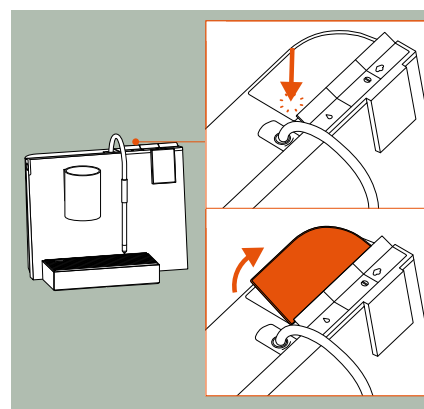

Rinse the machine:

1. As soon as the operating temperature is reached after just under 4 minutes, pull the steam button (right butterfly) forwards towards you and discharge steam into a container half-filled with water for 1 minute.



#### WARNING

Risk of scalding

Using containers that are too small can cause hot water vapour to escape.

- Select a container that is big enough to ensure that water vapour cannot escape and lead to scalding.
- Position the steam lance so that you or others are not scalded by any escaping steam.

- 
2. After 1 minute, tilt the butterfly back again.
    - ▶ The steaming process is ended.
  3. To start the “Exchanging boiler water” programme, tap the three dots at the top of the touchscreen. Select “Maintenance”, then select “Exchanging boiler water” and follow the instructions on the touchscreen until the end of the programme.
  4. Place a container (at least 0.5 litres), e.g. the large LIGRE milk jug, under the brew group.
  5. Make an espresso by pulling the centre butterfly forwards towards you until the LIGRE youn stops automatically. Then tilt the espresso butterfly back again.
  6. Empty the container and place it under the brew group again.
  7. Draw hot water by pulling the left butterfly forwards towards you until the LIGRE youn stops automatically. Then tilt the hot water butterfly back again.
  8. Empty the container again and place it under the brew group one last time.
  9. Please continue to make espresso until the tank is empty.
  10. Refill the water tank with fresh water and insert it into your LIGRE youn.
  11. Please repeat the entire rinsing process once.
    - ▶ The portafilter machine is now ready to brew your first espresso.

## 5 OPERATION

We have preset your LIGRE youn in such a way as to ensure that you get very good espresso in just a few simple steps. All you need for your first espresso is some ground coffee – preferably freshly ground LIGRE taha blend.

### 5.1 LIGRE GUIDE

The LIGRE guide is your personal assistant for operating your LIGRE youn. It can be a great help, especially at the beginning. It guides you step by step through the process of preparing coffee drinks, analyses the extraction and helps you to achieve the best possible result.

You can access the LIGRE guide at any time via the home screen.

1. Tap on the temperature display for the brew group on the left-hand side of the home screen.
  - ▶ The menu “Coffee settings” opens.
2. Select “Launch the LIGRE guide”.
  - ▶ You will now be guided through the operation.

Please note that the LIGRE guide is matched to the beans of the LIGRE taha blend. If other beans are used, the analysis may be inaccurate and consequently the recommendation may not be entirely accurate, as each bean type, blend and roast is different.

### 5.2 BREWING ESPRESSO

#### BREWING ESPRESSO IN LIGRE EASY MODE

LIGRE easy mode makes it particularly easy to brew very good espresso quickly and simply. We have carefully preset the most important parameters to ensure optimum and consistent coffee extraction: The brew temperature, the brew pause, the brew pressure and its progression during extraction as well as the amount of water.

1. Select your preferred brew profile from the LIGRE sensory profiles, as it has a major influence on the aroma and flavour of your espresso.
2. Tap the temperature display for the brew group on the left-hand side of the touchscreen.
  - ▶ The menu “Coffee settings” opens.
3. Select LIGRE sensory profile.

Here you can choose between the LIGRE sensory profiles brilliant bold, vibrant vigor and mellow morning. A description of the respective aroma and flavour can be found under 6.2 “LIGRE sensory profiles”.

4. Tap on your favourite profile to select it.
  - ▶ The last LIGRE sensory profile selected will be saved until you decide on a new one.
5. Place a cup under the brew group.
6. Press the hot water button (left butterfly) to preheat your cup with hot water. To cancel the hot water supply, press the hot water butterfly again.
  - ▶ If you do not press the button again, the hot water supply will stop automatically.
7. Fill the portafilter with ground coffee.
8. Compact the ground coffee with a tamper by pressing the ground coffee vertically downwards into the filter basket of the portafilter. Apply controlled, even pressure without twisting.
9. Clamp the portafilter into the brew group and turn the portafilter to the right until it is firmly seated in the brew group.
10. Place the emptied, preheated cup under the brew group.
11. Press the espresso button (centre butterfly) and select between single or double espresso on the touchscreen.
  - ▶ Your LIGRE youn starts the brewing process.
  - ▶ The brewing process is stopped automatically at the end of extraction.
12. If you want to cancel the brewing process prematurely, briefly press the espresso butterfly again.
13. As soon as the extraction is complete, you can remove your cup.
14. To remove the portafilter from the brew group, turn the portafilter to the left until it comes loose.
15. Remove the coffee puck from the portafilter by tapping it lightly against a knock-off box, for example the LIGRE Knockbox. To remove all coffee residue and oils, briefly rinse the portafilter under hot water immediately afterwards. This prevents residue from building up and affecting the flavour. With the help of a barista brush or a soft barista cloth, any fine residue can also be removed from the holes in the filter basket.
16. After brewing the espresso, we recommend briefly rinsing the brew group (also known as flushing) to remove coffee residue and oils. In easy mode, press the espresso button (centre butterfly).

You can find out more in 5.6, "Rinsing the brew group with LIGRE shpla".

If necessary, you can change the preset amount of water. You can find out more in 6.6, "Water quantity for hot water and espresso".

If you want to make a cappuccino or another coffee speciality with milk foam, you can prepare the milk foam at the same time as the espresso. You can find out more in 5.4, "Preparing milk foam".

## BREWING ESPRESSO IN LIGRE NERD MODE

In LIGRE nerd mode, those who like to experiment can set the most important brewing parameters for each espresso themselves and manually control the extraction time. The various setting options and the display of the brewing data on the touchscreen allow you to achieve your desired aroma and flavour.

1. Configure the desired settings for your espresso on the touchscreen.
2. Tap the temperature display for the brew group on the left-hand side of the touchscreen.
  - ▶ The menu “Coffee settings” opens.  
Here you can set the brew temperature, the brew pressure and the duration of the brew pause according to your preferences.
3. Tap on the parameter you want to set.
4. Scroll up or down on the touchscreen and confirm your setting with “OK”.
  - ▶ The brewing settings remain saved until you change them.
  - ▶ The value recommended by LIGRE is marked with a dot.
5. Place a cup under the brew group.
6. Pull the hot water button (left butterfly) towards you to preheat your cup with hot water. To stop the hot water supply, tilt the hot water butterfly to the rear.
7. Fill the portafilter with ground coffee.
8. Compact the ground coffee with a tamper by pressing the ground coffee vertically downwards into the filter basket of the portafilter. Apply controlled, even pressure without twisting.
9. Clamp the portafilter into the brew group and turn the portafilter to the right until it is firmly seated in the brew group.
10. Place the emptied, preheated cup under the brew group.
11. Pull the espresso button (centre butterfly) towards you.
  - ▶ Your LIGRE youn starts the brewing process.
12. You determine the extraction time yourself in nerd mode. You can end the extraction by tilting the espresso button back again.
13. Remove the cup from the portafilter machine.
14. To remove the portafilter from the brew group, turn the portafilter to the left until it comes loose.

15. Remove the coffee puck from the portafilter by tapping it lightly against a knock-off box, for example the LIGRE Knockbox. To remove all coffee residue and oils, briefly rinse the portafilter under hot water immediately afterwards. This prevents residue from building up and affecting the flavour. With the help of a barista brush or a soft barista cloth, any fine residue can also be removed from the holes in the filter basket.
16. After brewing the espresso, we recommend briefly rinsing the brew group (also known as flushing) to remove coffee residue and oils. In nerd mode, pull the espresso button (centre butterfly) towards you and tilt it back again to complete the process.

You can find out more in 5.6, "Rinsing the brew group with LIGRE shpla".

If you want to make a cappuccino or another coffee speciality with milk foam, you can prepare the milk foam at the same time as the espresso. You can find out more in 5.4, "Preparing milk foam".

### 5.3 CHANGING FLAVOUR AND TASTE

A perfect espresso is the result of a harmonious interplay of various factors – from the quality, freshness and roasting of the beans and the right grinding degree, to professional tamping and precisely set brewing parameters such as temperature, pressure and brew pauses, through to good water quality. This makes it possible to achieve a well-balanced result in terms of bitterness, acidity and sweetness.

The entire brewing process – from pre-infusion to the brew pause to extraction – should take around 25 to 35 seconds. Here you can find out what is important for optimal aroma and flavour development, and how you can influence it.

#### GRINDING DEGREE

The grinding degree has a major influence on the espresso quality, as it determines how many aromas and flavours are released from the ground coffee. A finer grinding degree slows down the water flow, as the water encounters more resistance. This increases the extraction time, which leads to more intense flavours and a stronger taste. However, if the grinding degree is too fine, the espresso can taste “over-extracted” and appear bitter or too strong. A coarser grinding degree allows the water to flow through the ground coffee more quickly and shortens the extraction time. This usually results in a milder, lighter flavour. If the grinding degree is too coarse, the espresso may be “under-extracted” and taste rather sour or flat, as fewer aromas and flavours are released.

A good coffee grinder is therefore an important counterpart to your portafilter machine. We recommend the LIGRE siji coffee grinder, which is perfectly matched to the LIGRE youn. Thanks to its grind by weight technology, you get the precise amount of ground coffee you need and the finely adjustable micrometric setting allows you to quickly find the right grinding degree.

### **BREW TEMPERATURE**

The acidic and bitter flavours present in coffee dissolve differently depending on the brew temperature, which has an effect on the taste. Acidic flavours are more easily soluble and are extracted at lower temperatures. A higher temperature extracts more flavour and aroma substances, which leads to more intense, often more complex aromas. However, if the temperature is too high, the coffee can become bitter.

With your LIGRE youn, you have the option of selecting a brew temperature between 86 and 99 °C; a temperature of 94 °C is preset as a recommendation. We recommend brewing at this temperature first and only then varying it if necessary.

### **BREW PRESSURE**

The brew pressure is responsible for dissolving the essential oils and thus for the variety of flavours and aromas. Too little brew pressure can lead to a watery, light-coloured and under-extracted espresso, as the aroma cannot fully develop. Excessive pressure has exactly the opposite effect. The espresso tastes very intense and the colour becomes darker. For a balanced flavour, balanced aroma and a beautiful crema, a brew pressure of 9 bar has proven its worth.

With your LIGRE youn, you have the option of selecting a brew pressure between 8 and 10 bar; a pressure of 9 bar is preset as a recommendation.

### **BREW PAUSE**

The brew pause is an important part of the brewing process. This is comprised of pre-infusion, the brew pause and the subsequent actual extraction. During pre-infusion, the coffee is only moistened briefly, the powder begins to swell evenly and the first flavours are released. During the brew pause, the water soaks into the ground coffee, causing it to swell further and activate additional flavours. The longer the brew pause, the more easily the aromas and flavours of the coffee are released and the more intense the espresso smells and tastes.

With your LIGRE youn, you have the option of selecting a brew pause with a duration of between 0.5 and 6 seconds; a duration of 2 seconds is preset as a recommendation.

## LIGRE SENSORY PROFILES

We have created three special brew profiles for the LIGRE youn: the LIGRE sensory profiles. Each of the brew profiles is based on precise control of the phases for the brewing process and the brewing parameters. By fine-tuning all factors, certain flavours can be highlighted and sweetness, acidity or bitterness emphasised. This allows you to brew your espresso to suit your individual taste.

You can find out more in 6.2, "LIGRE sensory profiles".

In addition to the above-mentioned possible settings on your LIGRE youn, the following parameters also influence the aroma and flavour of your espresso.

## EXTRACTION AND FLOW RATE

During extraction, hot water is forced through the saturated coffee grounds under high pressure, releasing the characteristic aromas and flavours and creating the crema for the espresso. The duration of the extraction is an important factor here. If the extraction time is shorter, the espresso tastes rather fruity, mild, acidic and has only a slight crema. If the extraction time is longer, the espresso tastes more intense and bitter, the roasted flavours come to the fore and the crema becomes richer. The extraction time is closely related to the flow rate. The flow rate, i.e. the amount of water per second that flows through the coffee puck, should be 1.8 – 2.4 ml/s for a very good espresso during extraction.

In LIGRE nerd mode, you can follow exactly how fast the water flows during extraction on the touchscreen and make adjustments to the grinding degree and brewing parameters if necessary. You can find out more in 5.2, "Brewing espresso in LIGRE nerd mode".

## WATER QUANTITY

The amount of water in your cup and the ratio to the coffee particles dissolved in the water also influence the aroma and flavour of the espresso. To summarise, the less water you use, the more intense your espresso will be. The parameter for this is the so-called brew ratio. The brew ratio describes the ratio of finished espresso in the cup to the amount of ground coffee in the portafilter. In the default settings for the LIGRE youn, we set the brew ratio for our LIGRE taha blend to 1:2.5. In words: 1 g of ground coffee produces 2.5 g of espresso in the cup. This brew ratio has been carefully tested and precisely defined by our developers and the Barista Team in order to offer both newcomers and experienced home baristas excellent espresso right from the start.

For a simple espresso, the LIGRE youn turns 11 g of ground coffee into 27.5 g or 27.5 ml of espresso. For a double espresso, 16 g of ground coffee is turned into 40 g or 40 ml of espresso in the cup. The LIGRE siji coffee grinder is also preset for precisely these quantities. Together with the LIGRE youn, you can easily achieve very good espresso in easy mode.

The common brew ratios for coffee drinks are

- Ristretto 1:1 to 1:1.5
- Espresso 1:1.5 to 1:2.5
- Lungo 1:2.5 to 1:4

### QUANTITY OF GROUND COFFEE

Like the amount of water, the amount of ground coffee in the brew ratio is another factor that contributes to a perfect espresso. Depending on your taste, use 7-11 g of ground coffee for a single espresso and 14-18 g for a double espresso. Here, too, you can experiment according to your own preferences. We recommend 11 g of ground coffee for a single espresso and 16 g for a double espresso.

### TAMPING AND CONTACT PRESSURE

The pressure with which you tamp the ground coffee in the portafilter has an effect on the extraction time and flow rate. If the tamping is too tight, the resistance of the water increases, which can prolong the throughput time and more undesirable substances may be extracted. If you do not tamp hard enough, the water will not find enough resistance and the contact time between water and ground coffee will be too short. The espresso tastes watery and bland.

The recommended contact pressure is approx. 15 kg, which you should use to compress the ground coffee. Make sure to tamp vertically in a downward direction. The tamper should not be turned, as this can cause channelling.

---

## 5.4 PREPARING MILK FOAM

With the Autosteam steam lance, the LIGRE foamer, you can turn milk and suitable milk substitutes into perfect milk foam.

---



### WARNING

Risk of burns

The steam lance becomes hot during operation.

- During operation, only touch the black protective casing on the steam lance.
- 



### WARNING

Risk of scalding

Using containers that are too small can cause hot water vapour to escape.

- Select a container that is big enough to ensure that water vapour cannot escape and lead to scalding.
  - Position the steam lance so that you or others are not scalded by any escaping steam.
- 



### NOTE

To make perfect milk foam, we recommend that you briefly draw steam before every preparation of milk foam. This will remove any condensation from the steam lance. To do this, briefly pull the steam button (right butterfly) forwards towards you and then tilt it back again.

---

### PREPARING MILK FOAM IN LIGRE EASY MODE

1. Fill a milk jug with milk or a milk substitute. Make sure that there is enough space in your container for the milk foam.
2. Place the milk jug on the drip tray.
3. Please dip the LIGRE foamer into the milk jug until the thin tip disappears completely under the surface of the milk, but does not touch the bottom. The fine black ring should be visible just above the surface of the milk.
4. Press the steam button (right butterfly).
5. Select the desired milk foam texture and milk temperature by scrolling up and down on the touchscreen. You can choose from 10 foam levels and 3 temperature levels.
  - ▶ Your LIGRE youn starts the frothing process.
  - ▶ The process is stopped automatically at the end of frothing.
6. To cancel automatic frothing, briefly press the steam butterfly again.

7. As soon as your LIGRE youn has finished foaming, remove the LIGRE foamer from the container.
8. Immediately after steam extraction, please wipe the LIGRE foamer with a damp microfibre cloth to remove all milk residue. This will save you trouble later on.
9. Rinse the LIGRE foamer for a few seconds by pressing the steam butterfly.

#### **PREPARING MILK FOAM IN LIGRE NERD MODE**

1. Fill a milk jug with milk or a milk substitute. Make sure that there is enough space in your container for the milk foam.
2. Place the milk jug on the drip tray.
3. Please dip the LIGRE foamer into the milk jug until the thin tip disappears completely under the surface of the milk, but does not touch the bottom. The fine black ring should be visible just above the surface of the milk.
4. Pull the steam button (right butterfly) forwards towards you.
  - ▶ Your LIGRE youn starts the frothing process. The current temperature of the milk foam is displayed on the touchscreen.
5. You can now further influence the milk foam quality yourself by adjusting the immersion depth and the position of the LIGRE foamer in your milk jug.
6. As soon as your milk foam has reached the desired quality, tilt the steam butterfly to the rear.
  - ▶ Steam extraction is stopped.
7. Remove the LIGRE foamer from the container.
8. Immediately after steam extraction, please wipe the LIGRE foamer with a damp microfibre cloth to remove all milk residue. This will save you trouble later on.
9. Rinse the LIGRE foamer for a few seconds by pressing the steam butterfly.

## 5.5 OBTAINING HOT WATER

We recommend preheating your cup with hot water, which will allow the aroma and flavour to develop even better and you can enjoy your coffee nice and hot. You also need hot water for other coffee drinks, such as a Caffè Americano, Caffè Lungo, or the like.

### OBTAINING HOT WATER IN LIGRE EASY MODE

1. Place a cup under the brew group.
2. Press the hot water button (left butterfly).
3. Select the desired amount of water. You can choose between two quantities.
  - ▶ Your portafilter machine dispenses the preset amount of hot water.
4. To cancel the hot water supply, press the hot water butterfly again.
  - ▶ Your LIGRE youn stops dispensing hot water automatically as soon as the selected amount of water has been dispensed.

If necessary, you can change the preset amount of water. You can find out more in 6.6, "Water quantity for hot water and espresso".

### OBTAINING HOT WATER IN LIGRE NERD MODE

1. Place a cup under the brew group.
2. Pull the hot water button (left butterfly) towards you.
  - ▶ Your portafilter machine dispenses hot water.
3. To stop drawing hot water, tilt the hot water butterfly to the rear.

## 5.6 RINSING THE BREW GROUP WITH LIGRE SHPLA

Using the espresso button, you can easily rinse the brew group with hot water. With LIGRE shpla, significantly more water flows through the brew group than with regular espresso extraction.

Rinsing, also known as flushing, helps you to clean the brew group quickly and efficiently and remove coffee residue after every coffee extraction.

### LIGRE SHPLA IN EASY MODE

1. Remove the portafilter from the brew group.
2. Press the espresso butterfly.
  - ▶ The brew group is rinsed with hot water. After approx. 15-20 seconds, depending on the LIGRE sensory profile set, and a brief interruption, LIGRE shpla mode starts and the brew group is rinsed.
  - ▶ LIGRE shpla appears on the display.
3. To cancel flushing beforehand, press the espresso butterfly again.
  - ▶ Your LIGRE youn ends the process automatically in easy mode.

### LIGRE SHPLA IN NERD MODE

1. Remove the portafilter from the brew group.
2. Pull the espresso butterfly forwards.
  - ▶ The brew group is rinsed with hot water. After approx. 15-20 seconds, depending on the LIGRE sensory profile set, and a brief interruption, LIGRE shpla mode starts and the brew group is rinsed.
  - ▶ LIGRE shpla appears on the display.
3. To stop flushing, tilt the espresso butterfly to the rear.

---

#### NOTE



LIGRE shpla is triggered automatically if no or too little pressure is built up in the brew group, or more precisely in the brew head. This happens if the coffee is ground too coarsely or if the amount of ground coffee is too small. When the portafilter is clamped with ground coffee, this means that the espresso is not extracted as usual and without pressure. Therefore, make sure you use the right grinding degree, the right amount of ground coffee and professional tamping. You can find out more in 5.3, "Changing flavour and taste".

---

## 5.7 EMPTYING THE DRIP TRAY

The drip tray is attached to your portafilter machine using a magnet. You can remove it by simply pulling it forwards.

When the drip tray is full, you can tell by the float protruding from the drip rack. In this case, please empty the tray.

1. Carefully remove the drip tray from the portafilter machine.
2. Remove the drip rack from the drip tray and empty it.
3. Please take the opportunity to clean the drip rack and drip tray under running water with a soft sponge.
4. Place the drip rack back on the drip tray. Make sure that the rack is correctly aligned.
5. Push the drip tray onto the portafilter machine until the magnet attracts the drip tray.

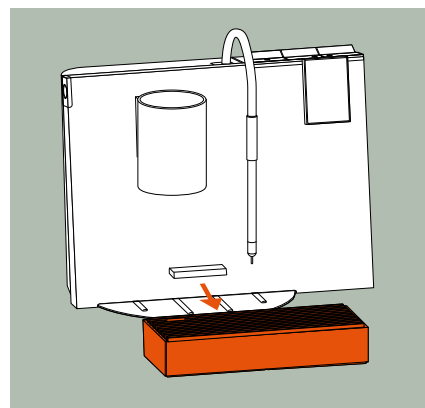

## 6 THE SETTINGS

If required, you can use the touchscreen to customise many of your LIGRE youn's settings according to your preferences.

These include the coffee settings with the individual brewing parameters (6.1) and the LIGRE sensory profiles (6.2), the boiler temperature (6.3), the milk foam texture and temperature (5.4) and the water quantities for hot water and espresso in LIGRE easy mode (6.6).

There are also other useful functions such as the timer (6.4) and LIGRE eco mode (6.5), which make life easier and help to save electricity. General settings such as language, time, date and water hardness can also be changed or the factory default settings can be restored (6.7).

### 6.1 BREWING PARAMETERS

You can individually set the brewing parameters for temperature, pressure and duration of the brew pause to influence the aroma and flavour of your espresso as you wish.

1. Tap the temperature display for the brew group on the left-hand side of the touchscreen.
  - ▶ The menu "Coffee settings" opens.
2. Select the brewing parameter you want to change: "Brew temperature", "Brew pressure" or "Brew pause". A brew temperature of 94 °C, a brew pressure of 9 bar and a brew pause of 2 seconds are recommended and preset.
3. Scroll up or down on the touchscreen and confirm your setting with "OK".
  - ▶ The brewing settings remain saved until you change them.
  - ▶ The value recommended by LIGRE is marked with a dot.
4. You can return to the home screen by tapping the three dots at the top of the touchscreen.

More information on the brewing parameters and other influencing factors can be found under 5.3 "Changing flavour and taste".

## 6.2 LIGRE SENSORY PROFILES

We have created three special brew profiles for the LIGRE youn: the LIGRE sensory profiles. Each of the brew profiles is based on precise control of the phases for the brewing process and the brewing parameters. The flavour profile of the espresso is varied here, especially during pre-infusion, and is influenced by the different amount of water used and the duration of the wetting of the coffee grounds with water. By fine-tuning all factors, certain flavours can be highlighted and sweetness, acidity or bitterness emphasised.

You can choose between the following LIGRE sensory profiles:

- brilliant bold for an intense, slightly bitter, chocolaty espresso.
  - vibrant vigor for a balanced aroma and flavour.
  - mellow morning for a milder, slightly acidic, fruity espresso.
1. Tap the temperature display for the brew group on the left-hand side of the touchscreen.
    - ▶ The menu “Coffee settings” opens.
  2. Select LIGRE sensory profile.
  3. Scroll up or down on the touchscreen and confirm your desired LIGRE sensory profile with “OK”.
    - ▶ The selected LIGRE sensory profile remains saved until you change it.
  4. You can return to the home screen by tapping the three dots at the top of the touchscreen.

## 6.3 BOILER TEMPERATURE

The steam for producing milk foam is generated in the boiler of your LIGRE youn. You have the option of selecting a boiler temperature between 120 °C and 130 °C. If you don't want to froth milk, you can also simply switch off the boiler to save electricity.

1. Tap on the temperature display for the boiler on the right-hand side of the home screen.
  - ▶ The menu “Boiler temperature” opens.
2. To switch the boiler on or off, tap the slider next to “Boiler”.
  - ▶ When switched on, the slider lights up brightly; when switched off, it is dimmed.
3. To set the temperature, tap on “Boiler temperature”. With your LIGRE youn, you have the option of selecting a boiler temperature between 120 °C and 130 °C; a temperature of 125 °C is preset.

4. Scroll up or down on the touchscreen and confirm your desired temperature with “OK”.
  - ▶ The selected temperature remains stored until you change it.
  - ▶ The temperature of 125 °C recommended by LIGRE is marked with a dot.
5. You can return to the home screen by tapping the three dots at the top of the touchscreen.

## 6.4 TIMER

We want to make using your LIGRE youn as easy and convenient as possible for you. You can use the practical timer on your LIGRE youn so that you can drink your first espresso first thing in the morning without having to wait, for example, or if you sometimes forget to switch off the portafilter machine in the evening. Once set to your requirements, you no longer need to worry about having to switch the portafilter machine on and off again in the evening.

1. Tap the three dots at the top of the touchscreen.
  - ▶ The main menu for the settings opens.
2. To switch the timer on or off, tap the slider next to “Timer”.
  - ▶ When switched on, the slider lights up brightly; when switched off, it is dimmed.
3. To set the timer, tap directly on “Timer”.
  - ▶ The menu item “Timer” opens.
4. Tap to select the days for which you want to store the same switch-on and switch-off times.
  - ▶ The selected days are underlined on the touchscreen.
5. To set the times for the timer, tap on the pencil icon in the top right-hand corner.
6. Tap the plus sign and set the switch-on time and switch-off time. Confirm the time with “OK”.

You can also set several times per day. To do this, simply tap the plus sign again after you have set a time pair.
7. Use the three dots in the top line to go back one point in the menu. Here you can activate or deactivate the timer for each day individually by tapping the slider to the left of the individual days.

8. To deactivate or completely delete an individual switch-on and switch-off time, first tap on the relevant day of the week and then on the pencil symbol in the top right-hand corner. You can now use the slider to the left of the switch-on and switch-off time to deactivate it (or activate it if it was previously deactivated). Tap the “X” to the right of the switch-on and switch-off time to delete this time.
9. You can return to the home screen by tapping the three dots at the top of the touchscreen.

## 6.5 LIGRE ECO MODE

To save energy, we have equipped the LIGRE youn with an intelligent energy-saving mode, our LIGRE eco mode. If LIGRE eco mode is activated, the temperature of the brew group and the boiler is automatically lowered after a period of time that you can set.

The home screen is dimmed in LIGRE eco mode. By tapping the touchscreen, your LIGRE youn heats up quickly and is ready for use again in just 1 minute.

1. Tap the three dots at the top of the touchscreen.
  - ▶ The main menu for the settings opens.
2. To activate or deactivate eco mode, tap the slider next to LIGRE eco mode.
  - ▶ When activated, the controller lights up brightly; when deactivated, it is dimmed.
3. To set the duration after which the LIGRE youn should switch to eco mode, tap on LIGRE eco mode.
4. During initial commissioning, a message about LIGRE eco mode appears on the touchscreen. After you have read it, confirm with “OK”.
  - ▶ The menu item “Activatation after” opens.
5. Scroll up or down on the touchscreen and confirm the desired time with “OK”.
  - ▶ The selected duration after which eco mode is to be activated remains saved until you change it.
6. You can return to the home screen by tapping the three dots at the top of the touchscreen.

## SWITCHING OFF ENERGY-SAVING MODE

To help you save even more energy when your LIGRE youn is not in use, there is an automatic energy-saving switch-off function. The LIGRE youn then switches to standby mode.

If the LIGRE youn has not been used for 8 hours and no LIGRE butterfly has been operated or the touchscreen touched, a corresponding message appears 10 minutes before it switches off. You have the option of selecting “Cancel process” on the touchscreen for the duration of the message. Your LIGRE youn then remains switched on and does not switch to standby mode.

## 6.6 WATER QUANTITY FOR HOT WATER AND ESPRESSO

The LIGRE youn allows you to preset the amount of water for hot water – for example for a Caffè Americano – and for espresso according to your preferences and cup sizes for the LIGRE easy mode.

You can save two quantities: for a little or a lot of hot water or for a single or double espresso.

1. Tap the three dots at the top of the touchscreen.
  - ▶ The main menu for the settings opens.
2. Select LIGRE easy mode.
  - ▶ The menu item LIGRE easy mode opens. Here you can set the amount of water for hot water and espresso.
3. For the hot water volume, tap on “little” or “a lot”, for the espresso water volume tap on “single” or “double”, read the message that appears and confirm with “OK”.
4. Scroll up or down to change the quantity if necessary and confirm with “OK”.
  - ▶ The last set water quantities remain stored until you decide on another volume.
5. You can return to the home screen by tapping the three dots at the top of the touchscreen.

## 6.7 GENERAL SETTINGS AND INFORMATION

1. For general settings and other functions and information, tap the three dots in the centre at the top edge of the touchscreen on the home screen.
2. The language, time, date and water hardness can be set under the menu item “General”. You can also reset your portafilter machine to the factory default settings there.
3. Under “Maintenance”, you can access the programmes for descaling, cleaning the steam lance, cleaning the brew group, replacing the boiler water and drainage transport.
4. Under “About this LIGRE youn” you will find the current software status under “Appliance” and information on the number of coffee, hot water and steam dispenses and the current degree of limescale under “Statistics”.
5. You can return to the home screen by tapping the three dots at the top of the touchscreen.

## 7 THE CLEANING AND MAINTENANCE

To ensure that you can always enjoy wonderfully aromatic espresso and milk foam, we highly recommend regular care and cleaning of your portafilter machine. This will also extend the service life of your LIGRE youn. Some of it is manual work. When descaling, cleaning the steam lance and cleaning the brew group, your LIGRE youn actively supports you thanks to the specially developed integrated cleaning programmes.

Even if a boiler water exchange or transport drainage is required, your LIGRE youn will guide you through the process.

---

### NOTE



At [ligre.com/service](https://ligre.com/service) you will find information and tutorials on cleaning with a variety of helpful how-to videos.

---

### NOTE



Unsuitable cleaning agents or incorrect dosages will damage your LIGRE youn. We recommend using LIGRE cleaning agents. LIGRE cleaning agents have been specially developed for your LIGRE youn and have been optimised for this portafilter machine. They enable optimum cleaning and ensure the longevity of your LIGRE youn.

---

### 7.1 CLEANING THE STEAM LANCE

#### IMMEDIATE CLEANING OF THE STEAM LANCE

Clean the steam lance after each foaming process. If milk residue remains on the steam lance, harmful residue can form and subsequent cleaning becomes considerably more difficult.

1. Immediately after steam extraction, wipe the steam lance with a wet microfibre cloth to remove any milk residue.
2. Flush the steam lance for a few seconds by pressing the steam button.

---

### WARNING



Risk of scalding

- Position the steam lance so that you or others are not scalded by any escaping steam.

## WEEKLY CLEANING

1. Prepare the LIGRE milk system cleaner:  
Add 25 ml of LIGRE Milk System Cleaner to 225 ml of water in a measuring cup with a capacity of 0.5 l.
  - ▶ A total of 250 ml of cleaning solution is produced at a ratio of 1:9.
2. To open the cleaning programme, tap on the three dots at the top of the touchscreen.
3. To start the programme for cleaning the steam lance, first tap on the three dots in the middle at the top of the touchscreen on the home screen.
4. Select the menu item “Maintenance”.
5. Select “Clean steam lance”.
6. Follow the instructions on the display.

### NOTE



In step 3/9 “Clean steam lance”, you will be asked to unscrew the cap from the steam lance and clean it. Please refer to the adjacent graphic.

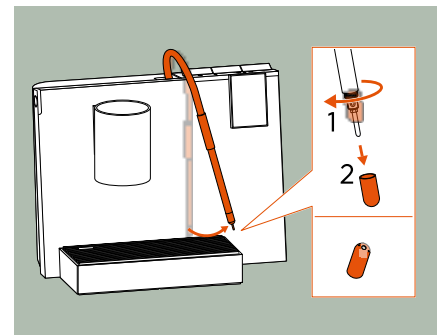

## 7.2 CLEANING THE PORTAFILTER MACHINE AND DRIP TRAY

The following components of your portafilter machine are made of plastic and are suitable for cleaning in the dishwasher:

- The water tank
- The inner shell of the drip tray
- The drip rack

**NOTE**



The portafilter, the filter baskets, the tamper and the aluminium drip tray frame are not suitable for washing in the dishwasher.

- Please clean these components carefully with a soft sponge under running water and never rub them with rough household sponges.
- 

We recommend cleaning the surfaces of the portafilter machine and its components at least once a week.

1. Switch off the portafilter machine and wait until it has cooled down.
2. Disconnect the power plug from the power supply.
3. Remove the drip tray from the portafilter machine and empty it if necessary.
4. Remove the drip rack and take the inner tray out of the drip tray.
5. Clean all parts under running water with a soft sponge. You can also clean the drip rack and the inner shell of the drip tray in the dishwasher without hesitation, but not the aluminium drip tray frame.
6. Dry the drip tray with a soft cloth.
7. Wipe the surfaces of the portafilter machine with a damp, soft cloth.
8. Clean the brew group with a damp cloth.
9. To avoid streaks, dry your LIGRE youn with a soft cloth.

### **7.3 CLEANING THE BREW GROUP AND PORTAFILTER**

The brew group should be cleaned once a week with LIGRE cleaning tabs for an average consumption of approx. 5-10 cups per day. This prevents changes in the aroma and flavour of espresso, cappuccino and other coffee drinks that would otherwise be caused by coffee residue in the brew group.

---

**NOTE**



When cleaning the brew group once a week, first clean it manually and then run the “Clean brew group” cleaning programme on your LIGRE youn.

---

#### **MANUAL CLEANING OF THE BREW GROUP**

For the following steps, you will need a stainless steel teaspoon or the blind filter as an aid.

To help you orientate yourself better, take a look inside the brew group from below before you start removing the individual parts.

**WARNING**

Risk of burns

The brew group and its components become hot during operation.

- Only clean the brew group manually when it is completely cold.
- Use a towel for protection when touching the brew group and its components.

1. Use the teaspoon or the blind filter to lift the shower screen including the black rubber seal (also known as the O-ring) out of the centre of the brew head and place it safely to one side.
2. Now carefully unscrew the slotted group dispersion screw from the bottom of the brew group using a 1 cent coin or simply by hand. Make sure that the group dispersion screw does not fall to the ground.
  - ▶ You should now have the group dispersion screw and the shower screen with the O-ring seal.
3. Carefully loosen the O-ring seal from the shower screen.
4. Clean the group dispersion screw, the shower screen and the O-ring seal with a soft washing-up brush under running water and then put everything safely to one side.
5. Use the cleaning brush available as an accessory and a damp cloth to clean the inside of the brew group:
  - Remove all coffee residue from the thread of the group dispersion screw in the centre of the brew head and the surrounding areas.
  - Clean the outer ring-shaped recess and the surrounding areas.

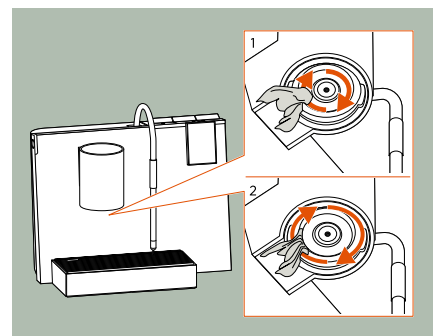
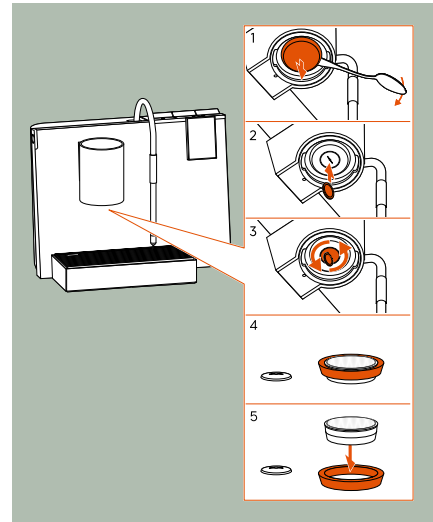

Replace all cleaned components – the group dispersion screw and the shower screen with O-ring seal – in the brew group.

1. Screw the group dispersion screw back into the centre of the brew group until it is tightly in place.
2. Place the O-ring seal around the shower screen again. Pay attention to the bevelled inside of the O-ring seal. Place the sealing ring around the shower screen so that the bevelled edge of the ring matches the bevelled wall of the shower screen exactly. This way everything fits securely and tightly.
3. Reinsert the shower screen with the O-ring seal into the brew group and secure it.

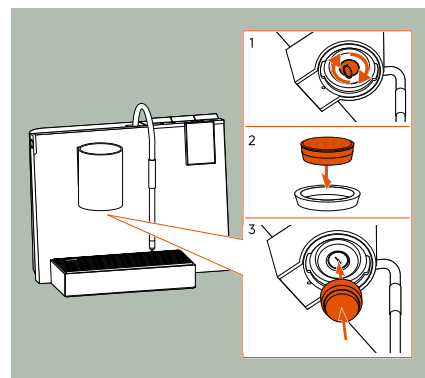

You have two options for this:

- Manually insert the shower screen and O-ring seal into the brew group as far as possible. Then take an empty portafilter (i.e. without a filter basket or blind filter) and clamp it in place to secure the shower screen and O-ring seal in the brew group. To be on the safe side, you can then clamp the portafilter with the filter basket once again, then the shower screen should be firmly in place.
  - Alternatively, you can also use a portafilter as an aid when inserting the shower screen and O-ring seal. To do this, place the shower screen and O-ring seal on top of the empty portafilter. Then clamp the portafilter in the brew group as usual and use it to fix the shower screen and O-ring seal in the brew head. To be on the safe side, you can also clamp the portafilter with filter basket again afterwards, then the shower screen should be firmly in place.
4. Take the blind filter and run the “Clean brew group” cleaning programme.

#### GUIDED CLEANING OF THE BREW GROUP

1. Have a LIGRE cleaning tab ready for the brew group.
2. To start the programme for cleaning the brew group, first tap the three dots in the middle at the top of the touchscreen on the home screen.
3. Select the menu item “Maintenance”.
4. Select “Clean brew group”.
5. Follow the instructions on the touchscreen until the end of the cleaning programme.

## CLEANING THE PORTAFILTER AND FILTER BASKETS

For the following steps, you will need a stainless steel teaspoon or the blind filter as an aid.

1. To clean the portafilter, lift the coffee filter out of the portafilter using a stainless steel teaspoon or the blind filter.
2. Remove coarse residue under running water with a soft washing-up brush.

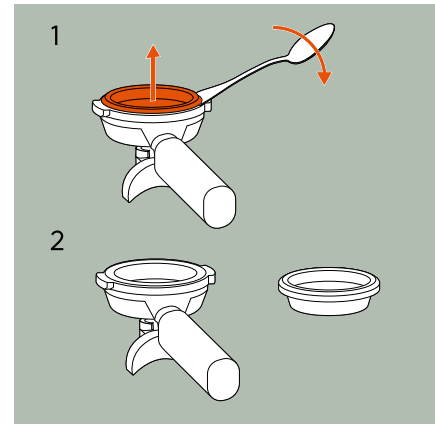

3. Fill a container with hot, but not boiling, water. You can use the steam lance on your LIGRE youn to heat the water to 60-70 °C in nerd mode.
  - ▶ The temperature sensor in the tip of the steam lance measures the temperature of the water, while the current water temperature is displayed on the touchscreen.
4. Place the portafilter and the filter basket in the hot water.

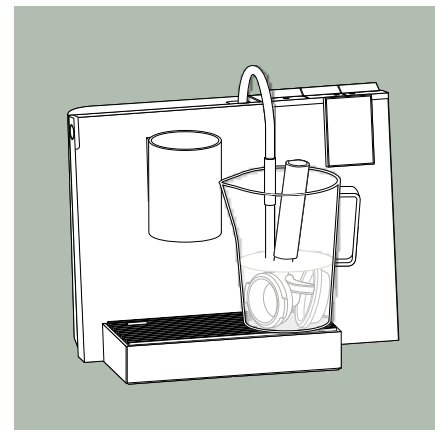

### NOTE



Make sure that the real wood handle does not get wet and does not stand in water.

5. Add two LIGRE cleaning tabs to the water.
6. Leave the cleaning solution to work on the portafilter and filter basket for 15-20 minutes.
7. Then rinse the portafilter and the filter basket thoroughly under running water.
8. Dispose of the cleaning solution and wash the container thoroughly.

## 7.4 DESCALING THE PORTAFILTER MACHINE

To ensure that your portafilter machine functions properly and to avoid irreparable defects that can be caused by hard water, you must descale the portafilter machine regularly and at specified intervals.

A message on the touchscreen shows you when descaling is recommended. You can find out about the current degree of limescale at any time. To do this, tap the three dots on the home screen at the top of the touchscreen, select “About this LIGRE youn” in the settings and then “Statistics”.



### WARNING

Risk of chemical burns  
Descalers are acidic.

- Observe the warnings on the descaler packaging.
- 



### NOTE

- Marble surfaces are negatively affected upon contact with the descaler. However, if splashes of descaler get onto the front of your LIGRE youn or onto a marble surface, remove them immediately with a soft, damp cloth.
  - Always stay close to your LIGRE youn during descaling. The drip tray and collection tray must be emptied several times during the process.
  - Please only use LIGRE descaling tabs and no other commercially available descaling agents. Pure citric and acetic acid are also not suitable for your LIGRE youn.
- 

1. Place the LIGRE descaling tab in the water tank.
2. Fill the water tank with cold water up to the maximum fill level and wait until the tab has completely dissolved.
3. To call up the descaling programme, first tap the three dots in the middle at the top of the touchscreen on the home screen.
4. Select the menu item “Maintenance”.
5. Select “Descaling”.
6. Follow the instructions on the touchscreen.
7. Finally, clean the brew group and portafilter manually as described in 7.3 “Cleaning the brew group and portafilter”.

## 7.5 REPLACING THE BOILER WATER

If you have not used your portafilter machine for some time, you should replace the boiler water that is still inside the portafilter machine before using it again.

1. To call up the programme to replace the boiler water, first tap the three dots in the middle at the top of the touchscreen on the home screen.
2. Select the menu item “Maintenance”.
3. Select “Exchanging boiler water”.
4. Follow the instructions on the touchscreen.

## 7.6 TRANSPORT DRAINAGE

Run the transport drainage programme if you want to completely empty the portafilter machine for transportation and send it in for servicing.

Even if your LIGRE youn is not used for a longer period of time and you have set it up in a garden shed or ski hut, the transport drainage programme helps you to prevent damage caused by freezing water.



### WARNING

Risk of scalding

During the transport drainage programme, hot water and steam escape via the drainage, the steam lance and the coffee outlet.

- Always position containers under the brew group and steam lance for protection during transport drainage, as described in the instructions on the display.
- Carefully remove and empty the filled drip tray so that you do not scald yourself or others with the hot water.



### NOTE

Temperatures below freezing will cause the water pipes and connections inside the portafilter machine to burst.

- Run the transport drainage programme if the direct ambient temperature of your unused LIGRE youn could fall below 0 °C.
-

1. To call up the transport drainage programme, first tap the three dots in the centre at the top of the touchscreen on the home screen.
2. Select the menu item “Maintenance”.
3. Select “Transport drainage”.
4. Follow the instructions on the touchscreen until the end of the programme.

## **7.7 MAINTENANCE**

To ensure long-term safe operation, we recommend that you have your LIGRE youn serviced by LIGRE Service every two years.

The LIGRE Customer Center will be happy to help you.

## 8 TECHNICAL DATA

|   |   |
|---|---|
| Type  | Portafilter machine youn  |
| Voltage                                     | 220-240 V ~ 50 Hz   |
| Power consumption (switched on)             | 2,300 W   |
| Power consumption (switched off)            | < 0.3 W   |
| Sound power level                           | < 70 dB(A)  |
| Brew pressure                               | 8-10 bar, adjustable  |
| Fresh water tank                            | 1.6 l   |
| Empty weight                                | 18.3 kg   |
| Width x height x depth                      | 450 x 401 x 304 mm  |
| Ambient temperature<br>for proper operation | +5 °C to +40 °C at max. 80% humidity  |
| Certification                               |  |

## 9 THE TROUBLESHOOTING

Here you will find an overview of possible faults, their causes and how to fix them.

| Fault  | Cause   | Troubleshooting   |
|--|---|---|
| Why does the brewing process not start?  | The water tank is not inserted correctly.   | Remove the water tank and insert it correctly.  |
|  | There are foreign objects in the water tank holder.   | Remove the water tank and clean the water tank holder.  |
|  | The filter basket in the water tank is clogged.   | Clean the water tank and the filter basket.   |
| Why is the machine still not at the target temperature after 4 minutes?  | The boiler is not switched on.  | Switch on the boiler.   |
| Why is the water tank not watertight or leaking at the bottom?   | The seal is dirty and no longer seals correctly.  | Clean the seal and put the water tank back into place.  |
| Why does an error message appear on the touchscreen during initial start-up or after replacing the boiler water? | There is air in the pipes.  | Confirm the warning with "OK" and draw hot water and coffee (without the portafilter) alternately until the air completely escapes. |
| Why is the espresso too cold?  | After the machine has heated up, not all water pipes are heated up, which leads to heat loss. | Make a single espresso twice in easy mode without the portafilter clamped in, with a 1-minute break in between.                     |
|  | The cup is cold.  | Preheat the cup with hot water.   |
|  | The portafilter is cold.  | Always leave the portafilter clamped in the brew group so that it is also heated up.  |
| Why does foaming take longer than usual?   | The amount of milk or milk substitute product is too large.                                   | Reduce the amount of milk in your milk container and start frothing again.  |

| Fault  | Cause  | Troubleshooting   |
|--|--|---|
| Why is the foam quality worse than usual?                                  | The protein content in the milk or milk substitute product is too low.               | Use a different type of milk and try special barista milk with a higher protein content.        |
|  | The milk has already become too hot and the properties of the proteins have changed. | Take fresh, cold milk and make sure that the milk does not get warmer than 65 °C when frothing. |
|  | The steam nozzle seal is defective or missing.                                       | Contact the LIGRE Customer Center to find out about replacing it.                               |
| Why is there too little steam or only water coming out of the steam lance? | The steam lance is dirty.  | Clean the steam lance. see page 33  |
|  | The steam lance or components required for steam production are calcified.           | Descale the portafilter machine. see page 39  |

**NOTE**

If you cannot fix the fault or the fault occurs frequently, we will be happy to assist you.

More on this in 12, "The LIGRE Service".

## **10 ON ENVIRONMENTAL PROTECTION AND ENERGY**

### **SAVING ENERGY**

If you do not use your portafilter machine for a period of time defined by you, it automatically switches to LIGRE eco mode.

You can set the time until your portafilter machine switches to energy-saving mode by selecting LIGRE eco mode under “Settings” and entering the desired time. You can find out more in 6.5, “LIGRE eco mode”.

Your LIGRE youn is also equipped with an automatic energy-saving switch-off function. You can find out more about this under LIGRE eco mode. You can also switch to standby mode by pressing the standby button.

If you are not planning to use your portafilter machine for a prolonged period of time, unplug it from the power socket. This way you can save even more energy and protect the environment.

### **KEEPING THE PACKAGING**

Please keep the original packaging for any subsequent dispatch for service or maintenance purposes.

If this is not possible, please dispose of the packaging material in accordance with your local waste management regulations and return the packaging to the recycling cycle. You are welcome to use the practical bag in which your LIGRE youn was delivered for other purposes. In doing so, you are helping to protect the environment and promote sustainability.

### **DISPOSING OF THE APPLIANCE**

If you should one day dispose of your portafilter machine, please do so in an environmentally friendly manner so that valuable raw materials can be reused. You can obtain information about current disposal options from your local government or city council.

## 11 THE WARRANTY

The statutory warranty for the LIGRE youn is 24 months from receipt of the goods. LIGRE accepts no liability for any consequences resulting from improper or non-design-conforming use.

In principle, damages or malfunctions caused by deposits or contamination are not covered by the manufacturer's guarantee or the statutory warranty. Furthermore, damages caused by limescale build-up or frost are also excluded from both the manufacturer's guarantee and the statutory warranty.

## 12 THE LIGRE SERVICE

Your satisfaction is important to us. Do you still have questions about your LIGRE youn? Do you require further information or support to make your coffee experience perfect?

You can contact us in various ways:

- send us a message via the contact form on [ligre.com](https://ligre.com)
- write us an email at: [wecare@ligre.com](mailto:wecare@ligre.com)
- call us at: +43 720 881239
- we can also answer you via WhatsApp on request

The LIGRE Customer Center will be happy to help and advise you.

---

### NOTE



On our website at [ligre.com/service](https://ligre.com/service) you will find lots of helpful information and how-to videos on operating and maintaining the LIGRE youn, as well as FAQs, instructions and other documents.

---

Version 1.1 (2025)

Subject to technical changes and errors.

Manufacturer:

LIGRE GmbH & Co KG · Innstraße 2 · A-6342 Niederndorf · Österreich